

08	Sous/ensemble mobile		1			
07	Tige Ø20x150		1	8.7	Tige Ø6	Lg.72 1
06	-	-	-	8.6	Tige frein Ø12	Lg.25 1
05	Disque estampé	Ø110x3	1	8.5	Cage à ressort	Ep.1.5 1
04	Tige fileté M12 x 200	DIN 975	1	8.4	Ressort Øext16 Øint13	Lg.30 1
03	Ecrou H m12	DIN934	1	8.3	Disque	Ø110x3 1
02	Tube Vertical	30x30x2	1	8.2	Tube Vertical	35x35x2 1
01	Tube Horizontal	35x35x2	1	8.1	Tube Horizontal	40x40x1.5 1
	<b>Désignation</b>	<b>Référence</b>	<b>Qté.</b>		<b>Désignation</b>	<b>Référence</b>
						<b>Qté.</b>

**SPI**  
SECURITE PERIPHERIQUE INDUSTRIE  
15 Place PAUL BERT  
64100 BAYONNE

DESIGNED BY:  
**F. FAHNER**  
DATE:  
**10/09/2020**  
SIZE  
**A3**  
SCALE  
**SANS**

<b>Désignation</b>	ART0149	F	-
<b>Matière</b>	S235JR	E	-
<b>Dimension</b>	suiwant plan	D	-
<b>Traitement</b>	Galvanisé à Chaud	C	-
		B	-
		A	-

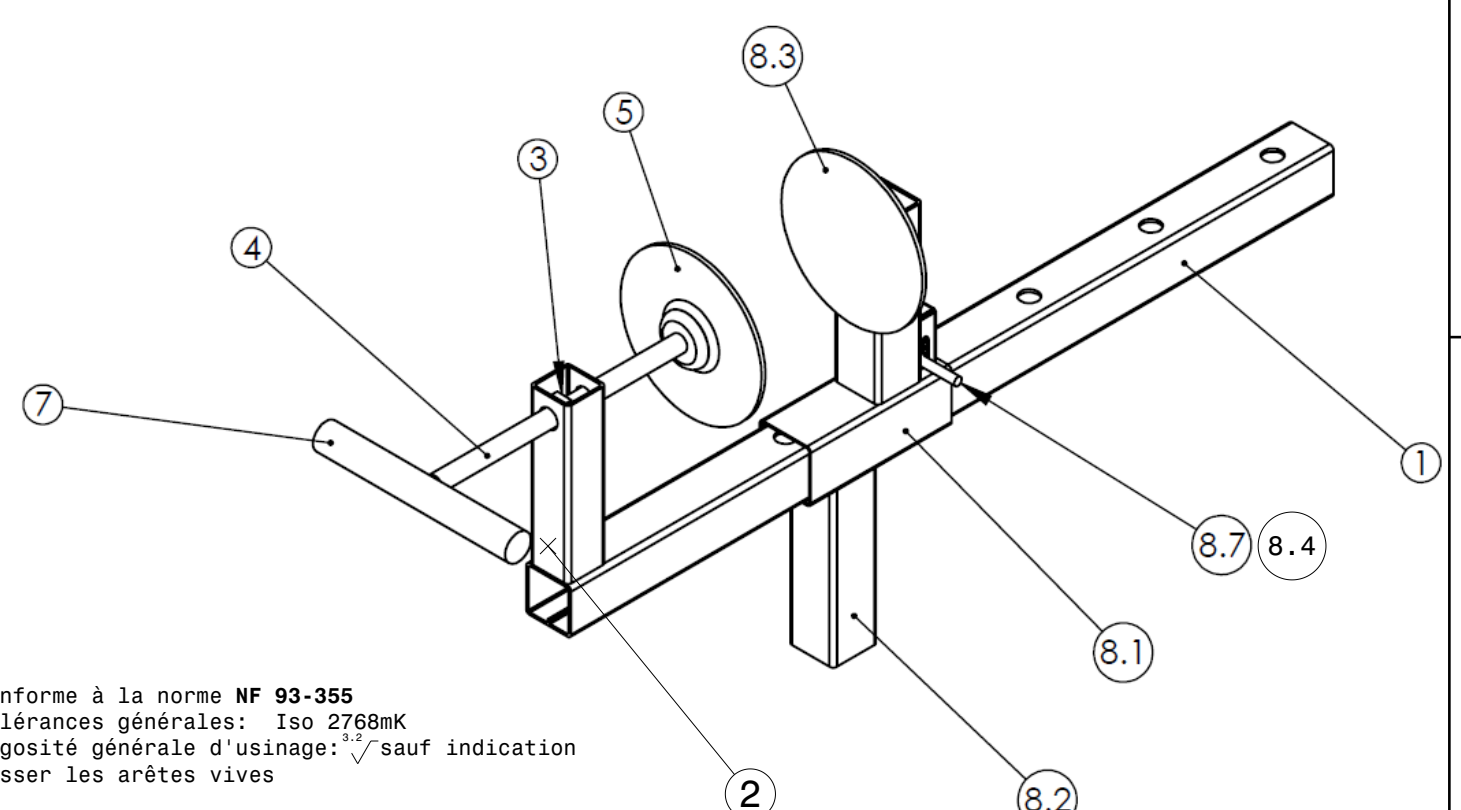

- Conforme à la norme **NF 93-355**  
- Tolérances générales: Iso 2768mK  
- Rugosité générale d'usinage:  $\sqrt{3.2}$  sauf indication  
- Casser les arêtes vives