

F G F E D C B A

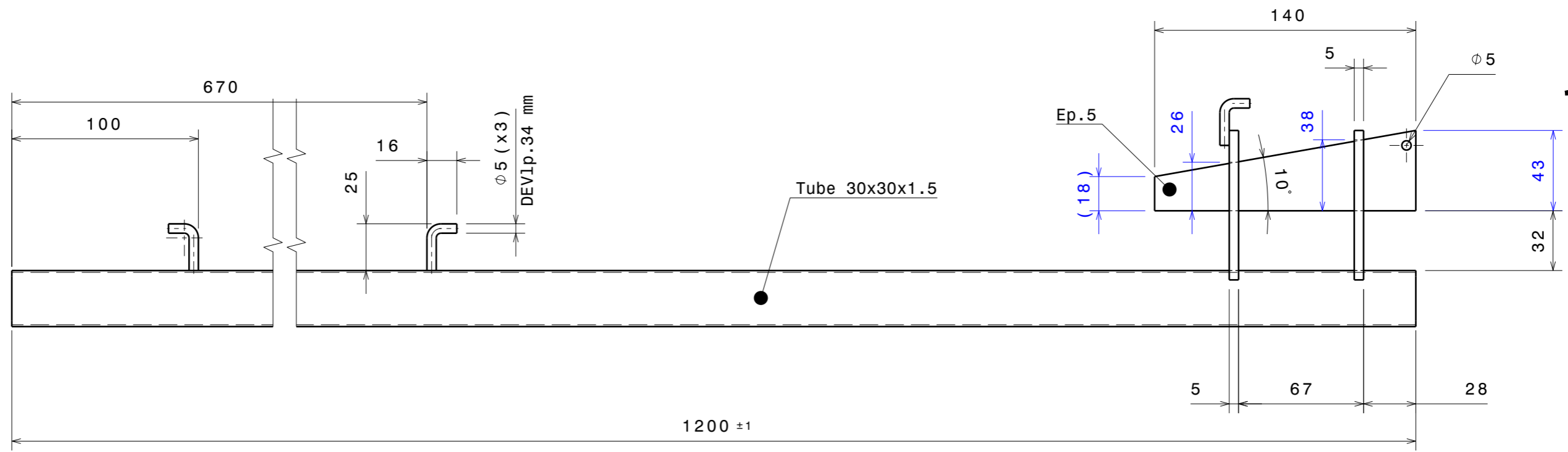

Vue svt F
Echelle : 2:5

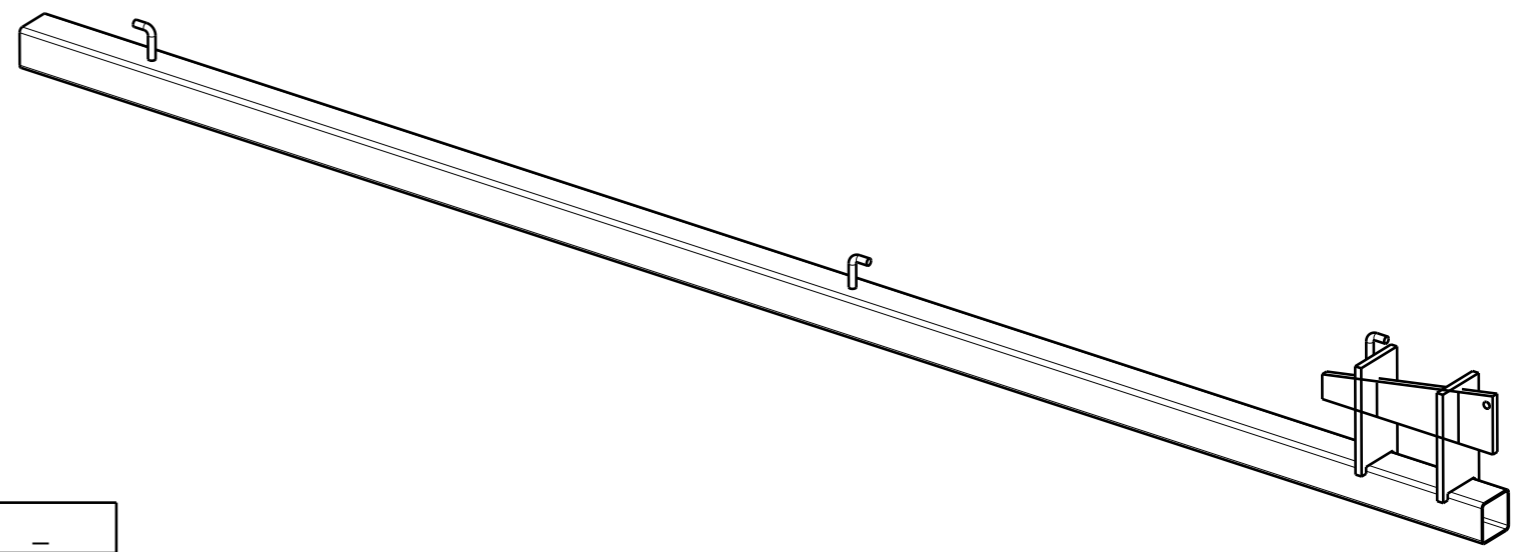
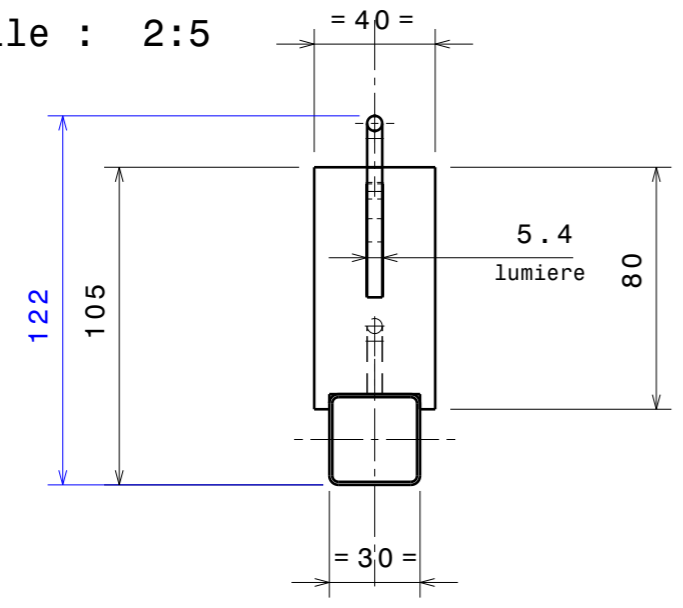

SPI

SECURITE PERIPHERIQUE INDUSTRIE
15 Place PAUL BERT
64100 BAYONNE

DESIGNED BY: F. FAHNER	Désignation	ART0024	F	-
DATE: 09/01/2020	Matière	S235JR	E	-
SIZE A3	Dimension	suivant plan	D	-
SCALE 2/5	Traitement	Zingué	C	-
WEIGHT (kg) 1.5			B	-
			A	-

- Conforme à la norme **NF 93-355**
- Tolérances générales: Iso 2768mK
- Rugosité générale d'usinage: $\sqrt{3.2}$ sauf indication
- Casser les arêtes vives

This drawing is our property; it can't be reproduced or communicated without our written agreement.

E D A